

S41

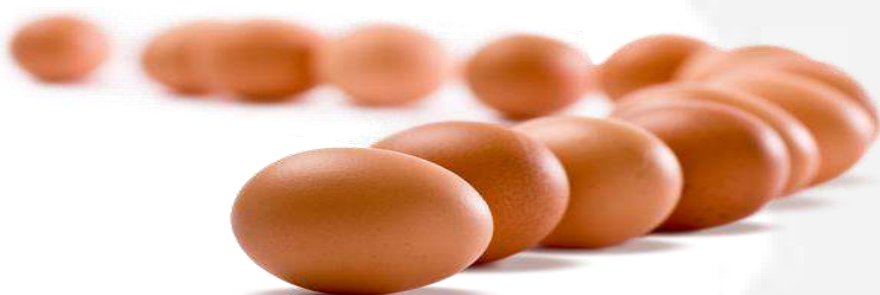

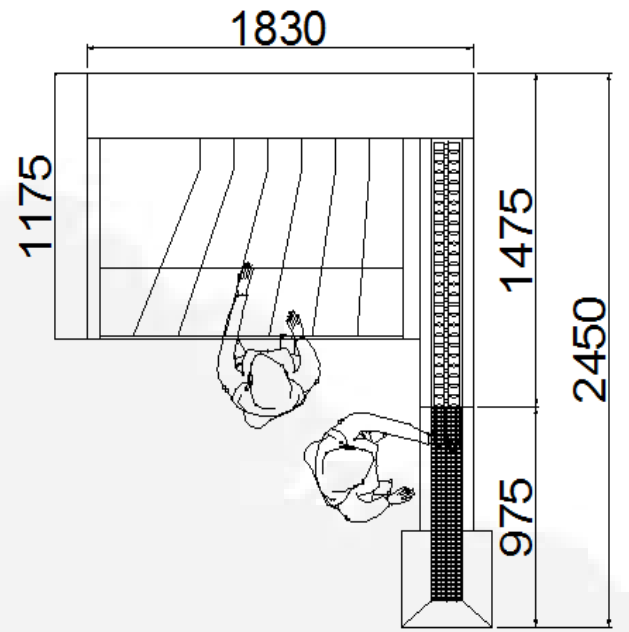

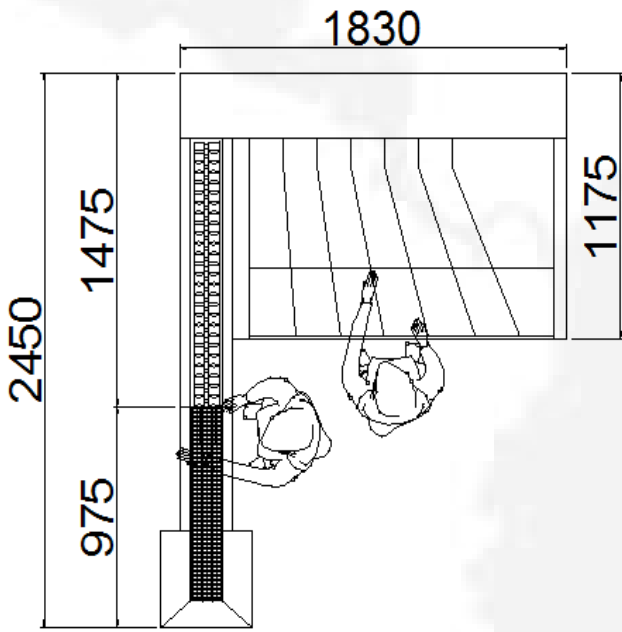
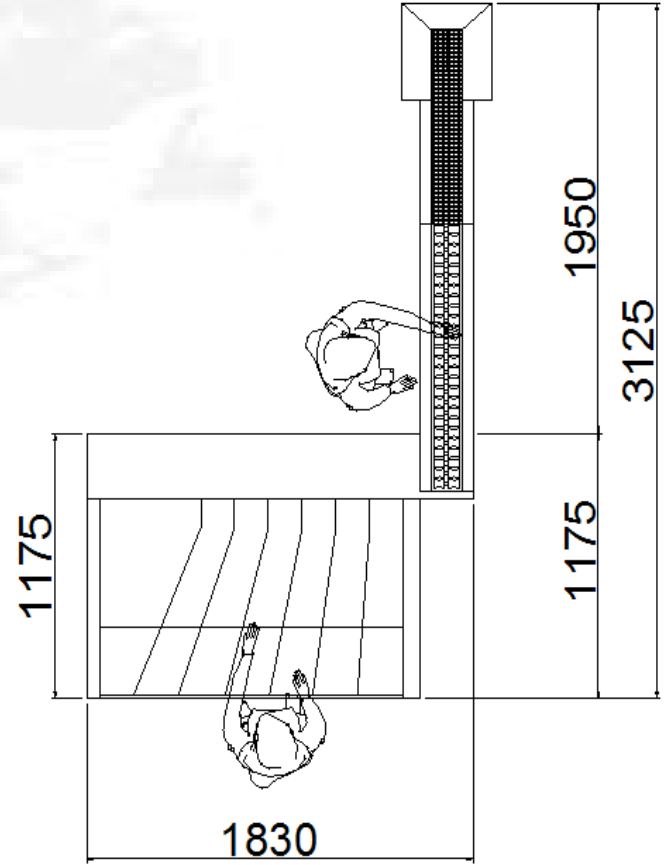
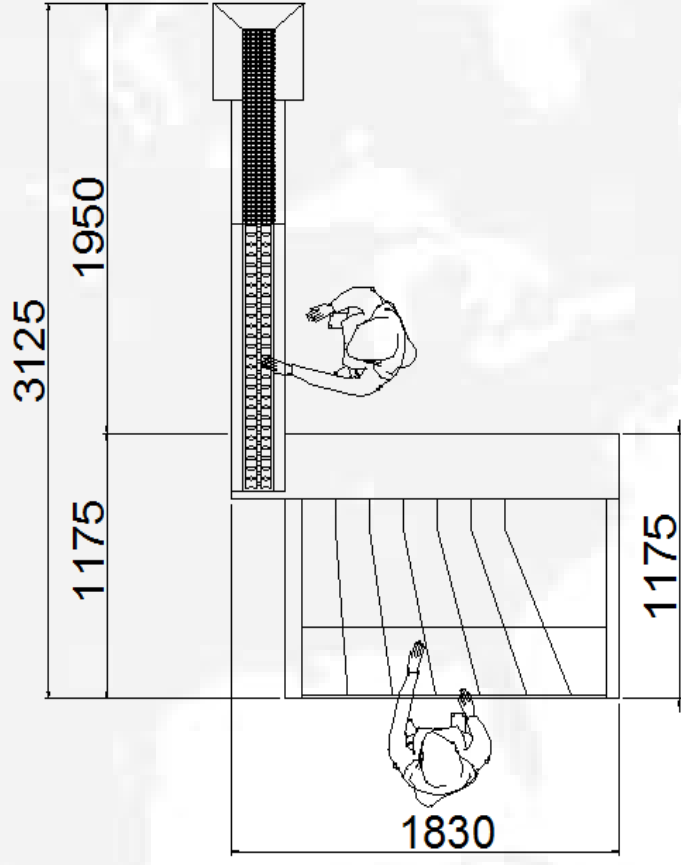
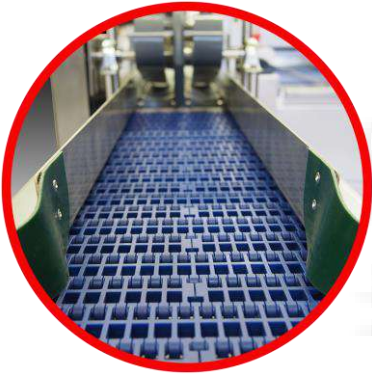

In line feeding conveyor with special modular chain belt made in food plastic material. Innovative and easy to clean.

The scales, in stainless steel, are the “heart” of the egg grader, for this reason they are designed and manufactured with extreme care and precision. The adjusting of the counterweight allows, for each particular needs, the individualization of any weight category.

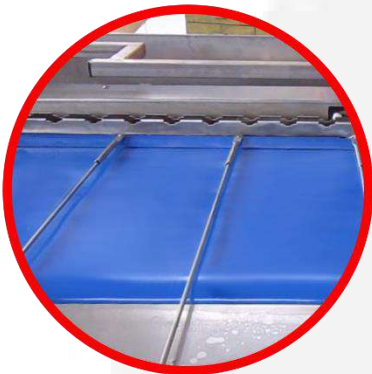

Synthetic egg belt and hand packing table with adjustable dividing lanes for all grades of seven weights

The table for collecting eggs can be equip also with a special modular chain belt made in food plastic material. Innovative system that allows to have greater resistance and is easy to clean.

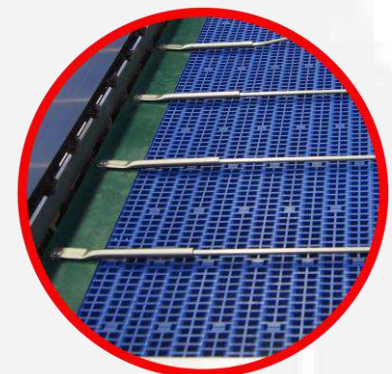

All Riva Selegg sorters are equipped, as standard, of a section dedicated for candling eggs with lamps. On demand are available different types of lamps



on egg grader can be installed an electronic system to counting the eggs

Egg grader type S 41

Capacity: 4.000 eggs/hour.

In line feeding conveyor for the direct supply from the belt coming from the cages or for semiautomatic loading with the hand vacuum lifter

Feeding with 2 rows of rubber rollers, candling system with two fluorescent lamps , with egg's rotating motion to simplify candling.

Grades in 7 classes with 12 precisely scales.

Synthetic belt to transport the eggs from the scales to the hand packing table. Adjustable sides for all grades.

Trays keeping shelf.

Electric power 230 Volts single phases, 50 Hz., 0.37 kW.

CONTACT US

Riva Selegg S.a.S. di Zampese Denis & C

Via delle Rogge, 4/a

33075 Morsano al Tagliamento (Pn) – Italy

Tel. +39 0434 697285

p.iva/vat 01500050933

info@rivaselegg.com

office@rivaselegg.com

www.rivaselegg.com