

S61

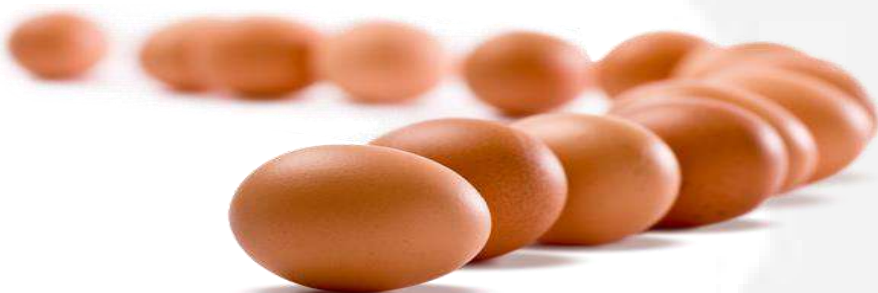

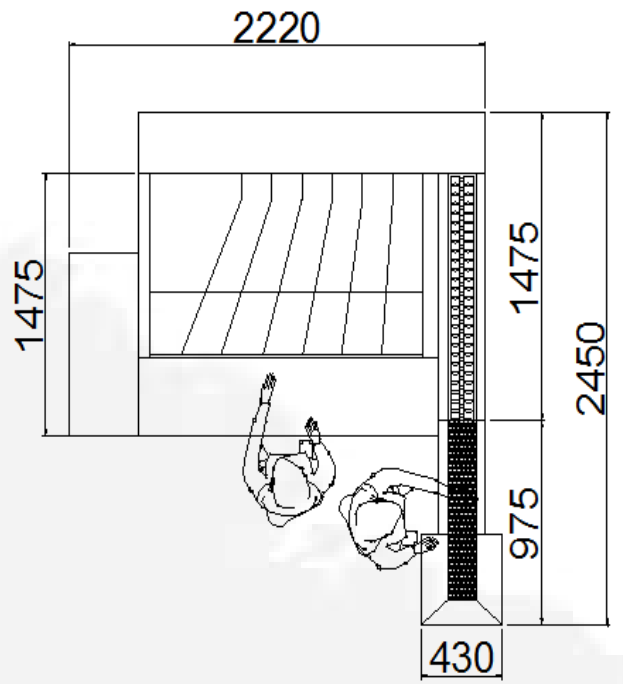

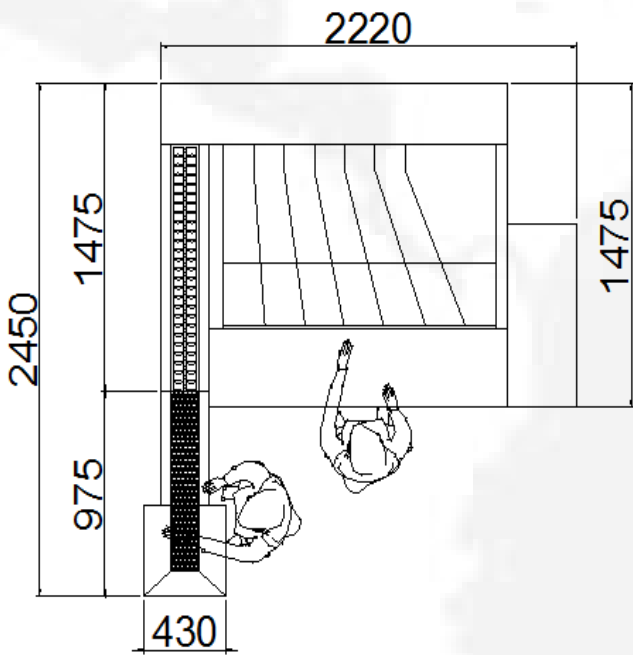
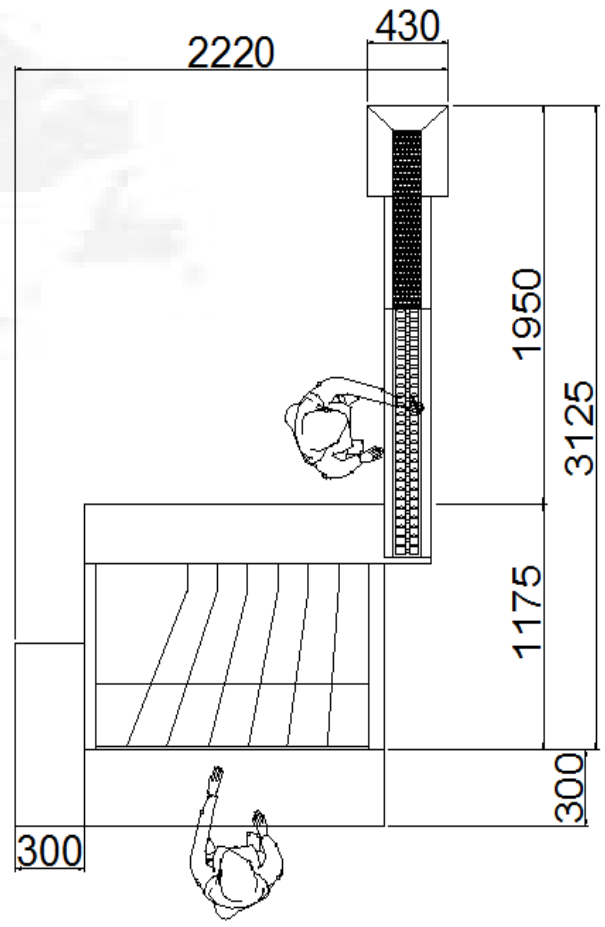
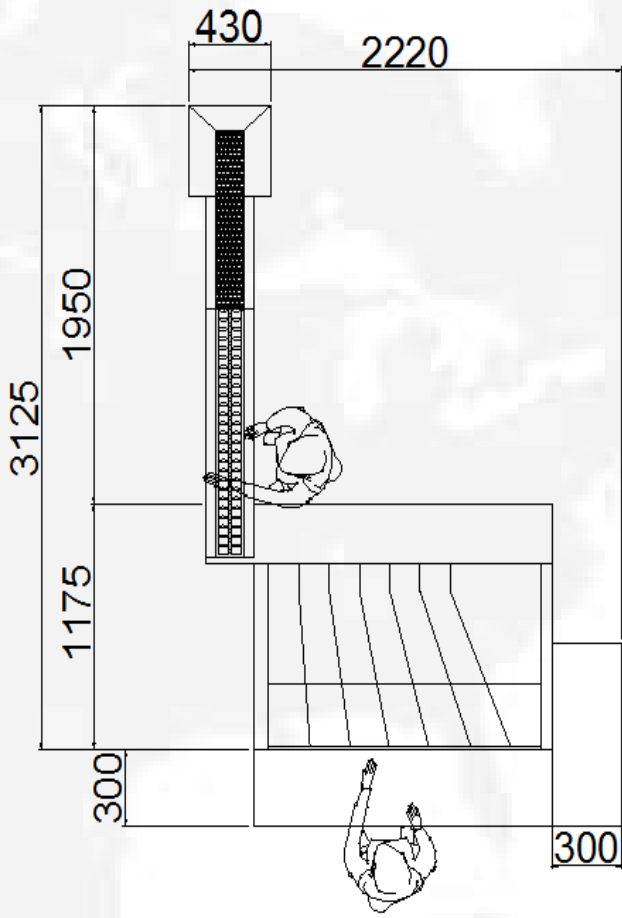
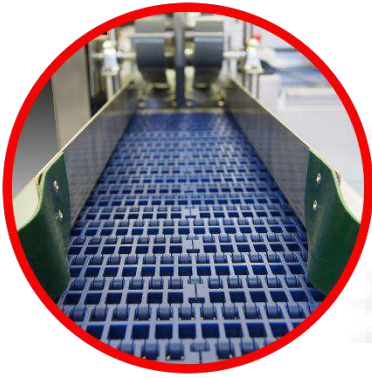

In line feeding conveyor with special modular chain belt made in food plastic material. Innovative and easy to clean.

The scales, in stainless steel, are the “heart” of the egg grader, for this reason they are designed and manufactured with extreme care and precision. The adjusting of the counterweight allows, for each particular needs, the individualization of any weight category.

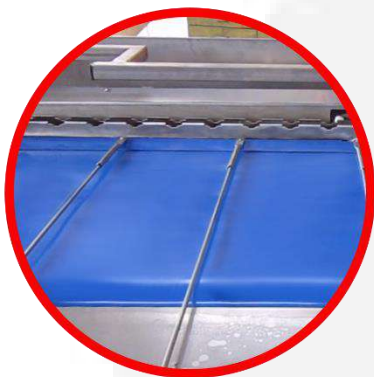
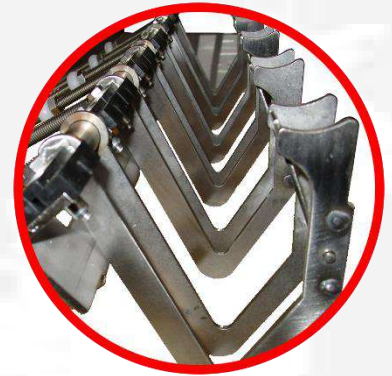

Synthetic egg belt and hand packing table with adjustable dividing lanes for all grades of seven weights

The table for collecting eggs can be equip also with a special modular chain belt made in food plastic material. Innovative system that allows to have greater resistance and is easy to clean.

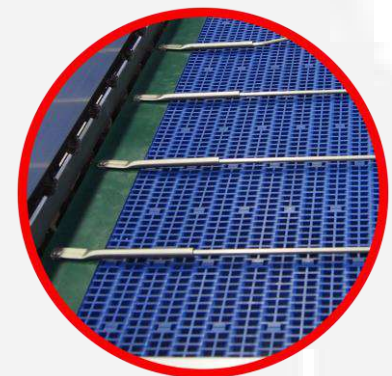

All Riva Selegg sorters are equipped, as standard, of a section dedicated for candling eggs with lamps. On demand are available different types of lamps  
on egg grader can be installed an electronic system to counting the eggs

# Egg grader type S 61

Capacity: 6.000 eggs/hour.

Special module in line feeding conveyor for the direct supply from the belt coming from the cages, or for semiautomatic loading with the hand vacuum lifter.

Feeding with 2 rows of rubber rollers, candling system with two fluorescent lamps , with egg's rotating motion to simplify candling.

Grades in 7 classes with 12 precisely scales.

Synthetic belt to transport the eggs from the scales to the hand packing table. Adjustable sides for all grades.

Trays keeping shelf.

Electric power  
400V, three phases, 50Hz  
230V, singlephase, 50Hz  
0.37 kW.

## CONTACT US

**Riva Selegg S.a.S. di Zampese Denis & C**

Via delle Rogge, 4/a

33075 Morsano al Tagliamento (Pn) – Italy

Tel. +39 0434 697285

p.iva/vat 01500050933

[info@rivaselegg.com](mailto:info@rivaselegg.com)

[office@rivaselegg.com](mailto:office@rivaselegg.com)

[www.rivaselegg.com](http://www.rivaselegg.com)